

ENGINEERING CHANGE ORDER		
Item#	DESCRIPTION	DATE
00	ORIGINAL	5/17/99
01	M3 TAPPED HOLES USE TO BE 0.098 COUNTER SUNK THROUGH HOLES, ADDED 0.05" FILLET RADIUS TO GUIDE SLOT	1/12/01

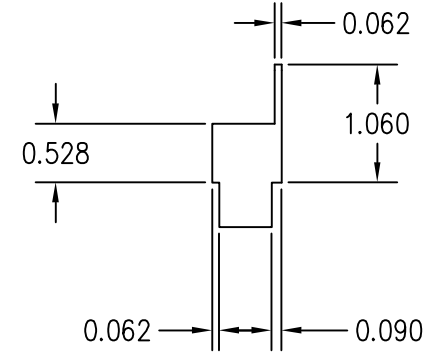
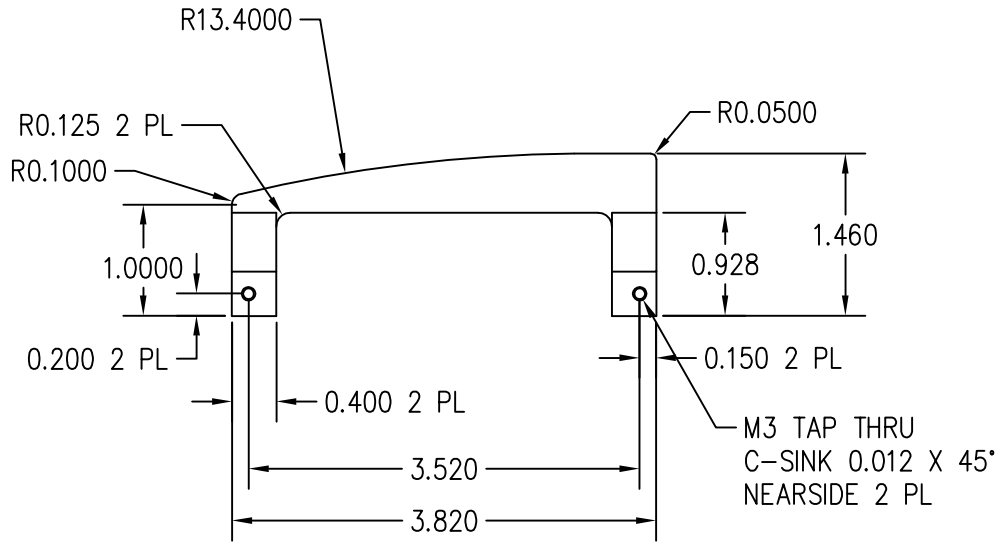
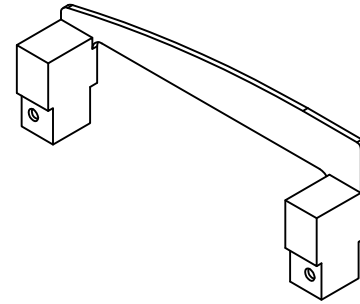
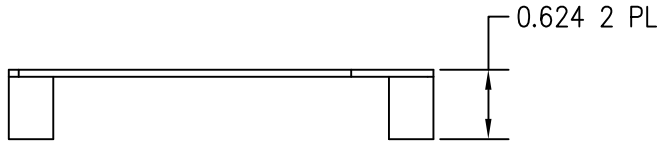

TOLERANCES:
 STD. TOL'S. +/- 0.010
 RAD. TOL'S. +/- 0.010
 HOLE TOL'S. +/- 0.005
 MAT. TOL'S. +/- 0.002

MATERIAL: 6061 T6 ALUMINUM

FINISH: BLACK ANODIZE

CONTRACT NO:

APPROVALS: _____ DATE: _____

DRAWN BY: VW DATE: 1/12/01

CHECKED: _____

COPYRIGHT PROTECTED

Gompf

SCALE: 1:1

GOMPF BRACKETS, INC.
 1410 19TH AVE N.W.
 Issaquah, Wa 98027
 Phone: (425) 391-0495 Fax: (425) 391-0496

DWG. NO. 9111-0000 RETAINER REV. 0